

# NKD

OWNER'S MANUAL

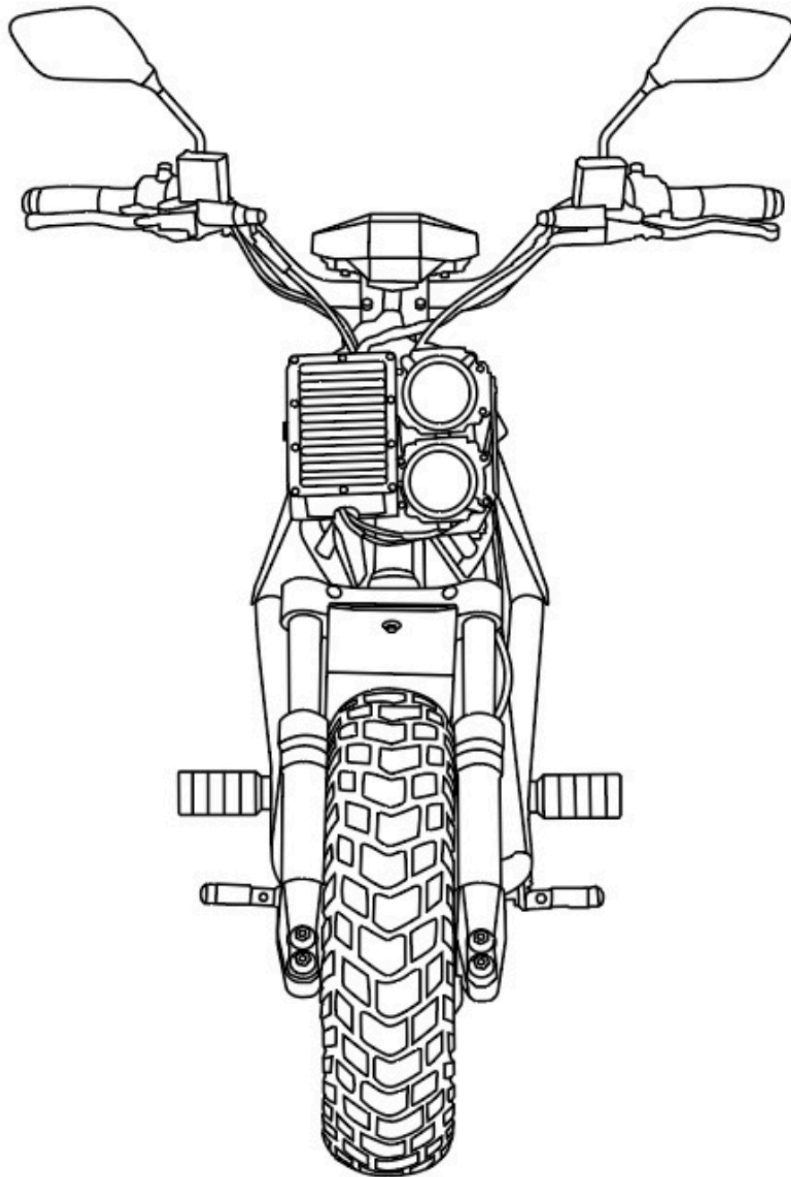

# Welcome to

# FONZ

Welcome to the Fonz community - you've just taken a positive step in reducing your carbon footprint.

Fonz runs solely on electricity. Zero Emissions Vehicles (ZEVs) are the only vehicles that get cleaner in terms of air pollution each year, as the electricity grid gets cleaner and more renewable. ZEVs offer greater efficiency, and can help solve the serious air pollution, global warming, and energy security problems faced today.

Through our collective effort we will electrify Australia's roads!

Now it's time to get to know *your* electric ride.

# Important Information

This manual is designed for optimal care of yourself while riding and optimal care for your NKD, both on and off road.

When you see the ⚠ **WARNING** symbol, special attention should be paid.

This manual also contains tips to help you get the most out of your ride.



## **HIGH VOLTAGE**

The high voltage warning sticker is located in various locations on your NKD. The high voltage symbol is there to inform you that exposure to high voltage can cause shock, burns, and even death. The high voltage components on the motorcycle should only be serviced by specially trained Fonz Moto technicians. High voltage cables and wiring have an orange-colored insulation. **NEVER** probe, tamper with or modify high voltage cables or wiring. If you have any concerns regarding the vehicle Powertrain performance, immediately contact Fonz Moto Pty Limited customer service.

## Parts and Accessories

**CAUTION:** Only use Fonz Moto approved parts and accessories for your NKD. Parts and accessories for your NKD have been checked and tested for safety and suitability. Fonz Moto is unable to accept any liability whatsoever for parts and accessories that have not been approved for use on your NKD vehicle.

# Content

<b>Important Information</b>	<b>3</b>
<b>Safe Riding &amp; Safety Precautions</b>	<b>4</b>
<b>Pre-Ride Inspection</b>	<b>6</b>
<b>Equipment</b>	<b>6</b>
Left Side View	7
Handlebar Switches	7
Handlebar Controls	7
Speedometer / Display	7
Switch blocks	8
<b>Vehicle Identification</b>	<b>8</b>
VIN Number	8
Motor serial number	9
Compliance plate	9
Powerpack serial number	11
Digital Key / Key	11
<b>Range &amp; Performance</b>	<b>14</b>
Maximising Range	15
<b>Starting procedure</b>	<b>15</b>
Riding	15
Braking	15
Adjusting Brake Levers	17
Reverse & Parking	17
Regenerative braking	17
Regenerative Display	17
Power modes	17
Riding off-road	18
Foot Pegs	18
Parking	18
<b>Charging &amp; Powerpack</b>	<b>18</b>
Powerpack Safety & Important Information	18
External Charging Port	20
Mini charger	20
Premium charger	20
Fast charger (only available for NKD+ and NKDx)	20
Onboard Charger	20
Charging Indoors	20
Removing Powerpack	21
Charger Specifications	21

Charger Operation	22
External Charger Safety Information	23
<b>Suspension</b>	<b>23</b>
Rear Mono Shock Absorber	23
Spring Preload Adjustment	24
Rebound Adjustment	24
Compression Damper	25
<b>Tyres &amp; Wheels</b>	<b>25</b>
Tyre Inflation	25
Tyre Tread Depth	25
Tyre Care and Replacement	25
<b>Storage, Convenience &amp; Accessories</b>	<b>26</b>
Under saddle storage compartment	27
Front storage	27
Optional Accessories	27
Bag Mounts	27
Bag Mounts	27
Tank Bag	27
Smartphone Mounts	27
Saddle plate	27
Mirror handlebar / mount	27

# Safe Riding & Safety Precautions

- NKD is a performance vehicle and should be ridden with extreme caution
- Obey all road regulations
- Ride in a manner befitting road condition
- Keep your hands and feet fixed firmly to the vehicle at all times when riding
- Always take extra caution at intersections, in high traffic situations, and when lane filtering
- Your safety depends in part on the good mechanical condition of the vehicle. Follow the [Fonz Moto Service Schedule](#)
- A compliant motorcycle helmet must be worn at all times when riding. Wearing a rider jacket, gloves and boots is strongly advised
- Ensure that you hold the required rider licence for your state or territory
- It is your responsibility to follow the local road rules in your state or territory. Fonz Moto does not accept liability for not adhering to local road rules. Local road rules and tips can be found on the website of your local transport authority
- Be responsible on the road. Persons unwilling or unable to take responsibility for their actions should not use this vehicle. You assume all responsibility while operating your NKD. The seller assumes no liability for misuse or operator negligence
- Be responsible off the road. Failure to follow Powerpack storage and charging instructions as described in this Owner's Manual may void the warranty of your Fonz vehicle. These guidelines have been rigorously tested to ensure maximum Powerpack efficiency, life and safety
- Follow the instructions for [Powerpack Safety & Important Information](#)
- Never lend your vehicle to an inexperienced rider, nor allow any individual to ride your NKD without proper instruction of the unique features of the vehicle
- Prior to each use the rider must check everything in the "pre-ride ride" section, and the charge level of the power pack as indicated on the dash display charge indicator
- Never ride in another driver's "blind spot"
- Above all, ride to live; employ common sense in all traffic situations

## What is Lithium Ion?

The PowerPack in your NKD utilises high quality lithium technology; the forefront of rechargeable cell technology with superior reliability, recharging time and power to weight ratio.

The PowerPack does not develop "charge memory" so you can recharge as frequently as it is convenient to do so.

Lithium Ion is an environmentally sustainable, recyclable technology and does not use heavy metals like mercury or cadmium found in other batteries.

Fonz Moto recycles lithium cells used in prototyping and manufacturing in applications such as second life.

# Pre-Ride Inspection

A pre-ride inspection will only take a few minutes and should be conducted before you ride the vehicle

1. Drive Belt. Check belt tension and condition. Adjust if necessary
2. Brakes – squeeze the brake levers to check for correct operation; make sure there is no fluid leakage
3. Tyres – check condition and pressure
4. Lights and Indicators – check for correct operation
5. Throttle – check for correct and smooth operation
6. PowerPack – ensure the PowerPack is correctly fitted, and cables correctly attached. Check

charge level is sufficient for distance of travel.

Ensure the vehicle is operating soundly before you ride. Contact an authorised Fonz Moto representative if you require assistance to resolve any issue or concern.

**⚠ WARNING**

If pre-ride inspection is not conducted before using the vehicle, damage to equipment or severe injury could result.

# Equipment

## Right Side View

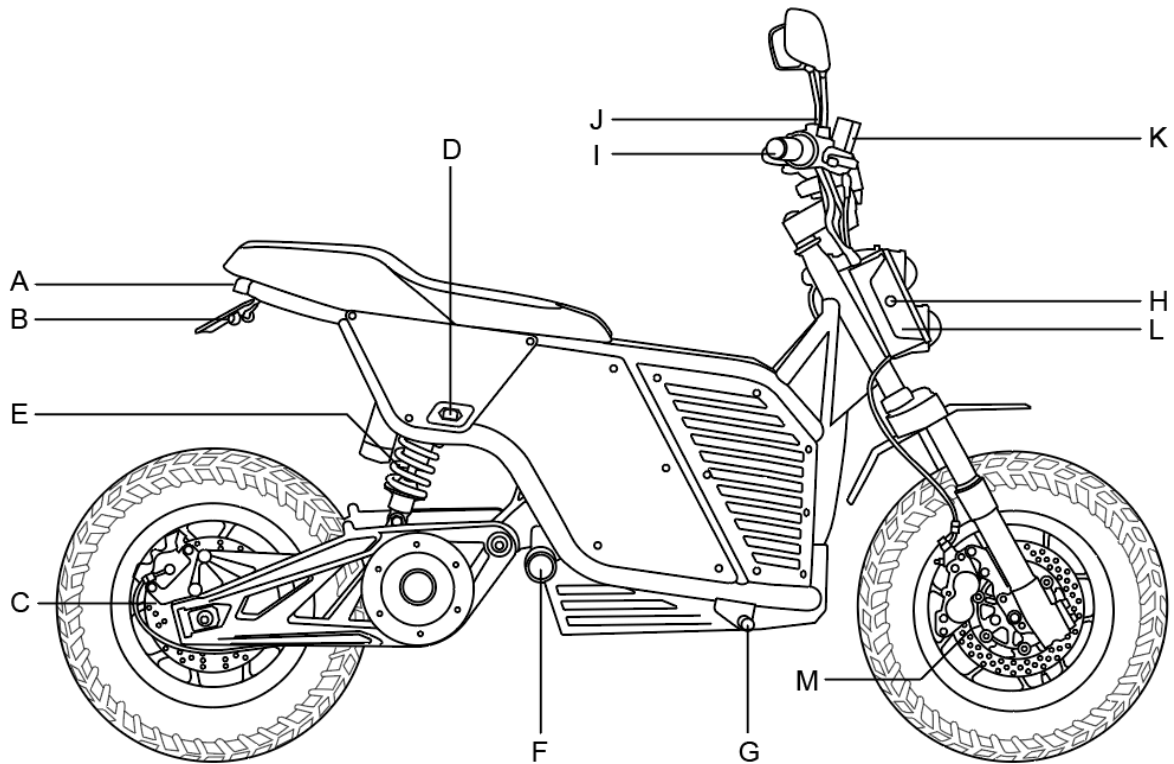

- A. LED Taillight, Brake Light and Plate Light
- B. LED Turn Signal, Rear
- C. Brake Caliper & Disc, Rear
- D. [External Charging Port](#)
- E. [Mono Shock Absorber, Rear](#)
- F. Foot Peg, Rear
- G. Foot Peg, Front
- H. LED Turn signal, Front
- I. LED Bar End Turn Signal (optional)
- J. Mirrors, Handlebar
- K. Front Master Cylinder / [Adjustable Brake Lever](#)
- L. [Control Box](#)
- M. Brake Caliper & Disc, Front



## Left Side View

- A. Drive belt (tension adjustor behind axle)
- B. Headlamp
- C. Rear Master Cylinder / [Adjustable Brake Lever](#)
- D. Onboard Charger & Input Port (option)
- E. USB Charge Port (option)
- F. Powerpack
- G. Override Switch (digital key only)
- H. Sidestand

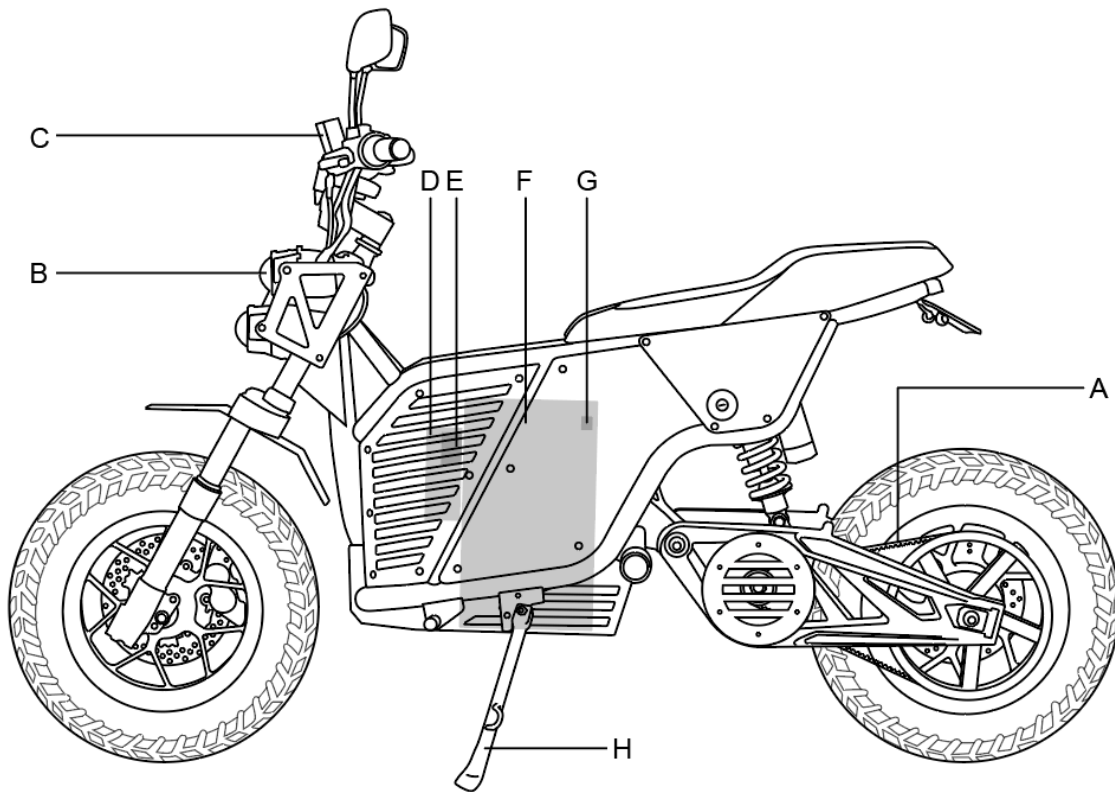

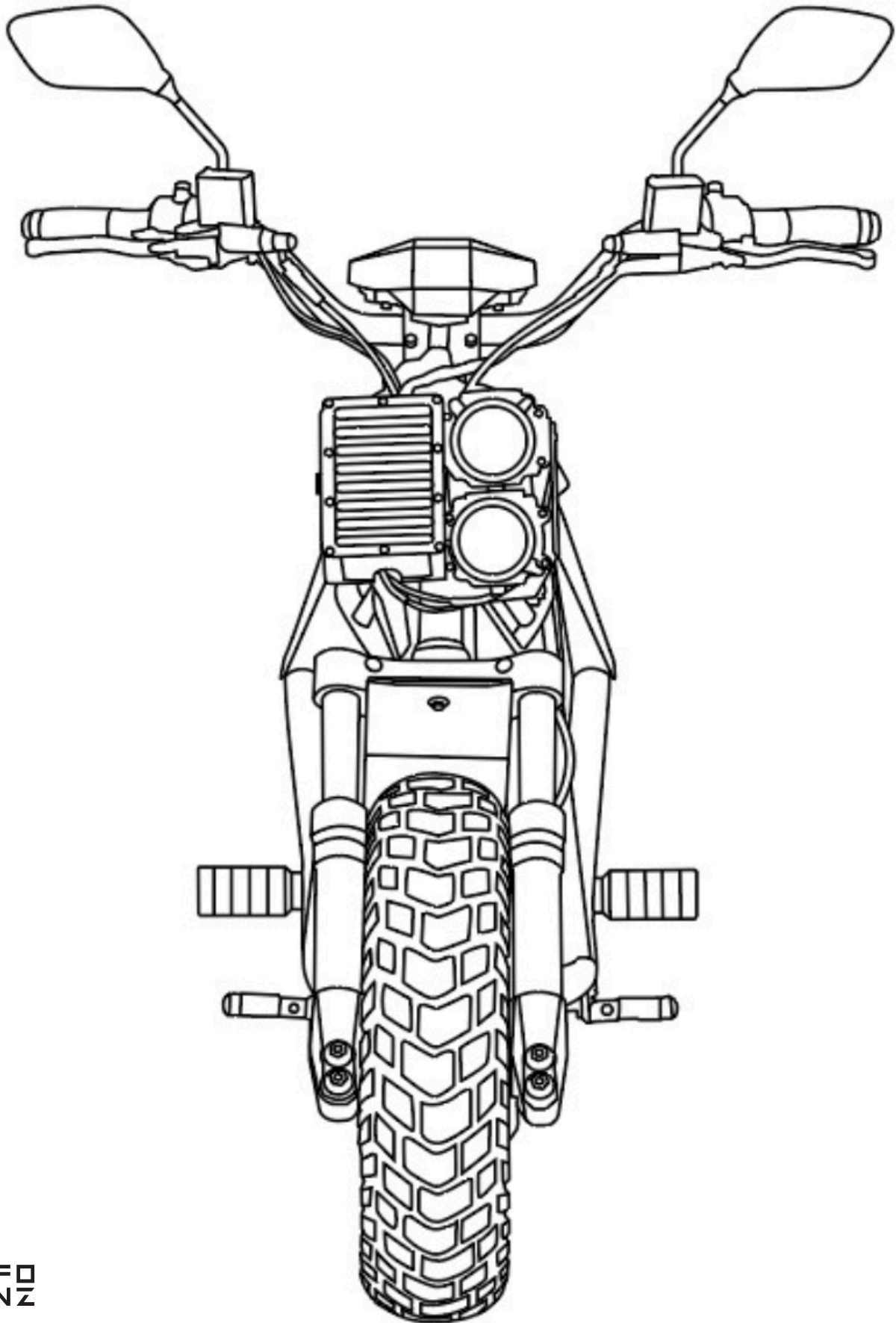

## Handlebar Switches

## Handlebar Controls

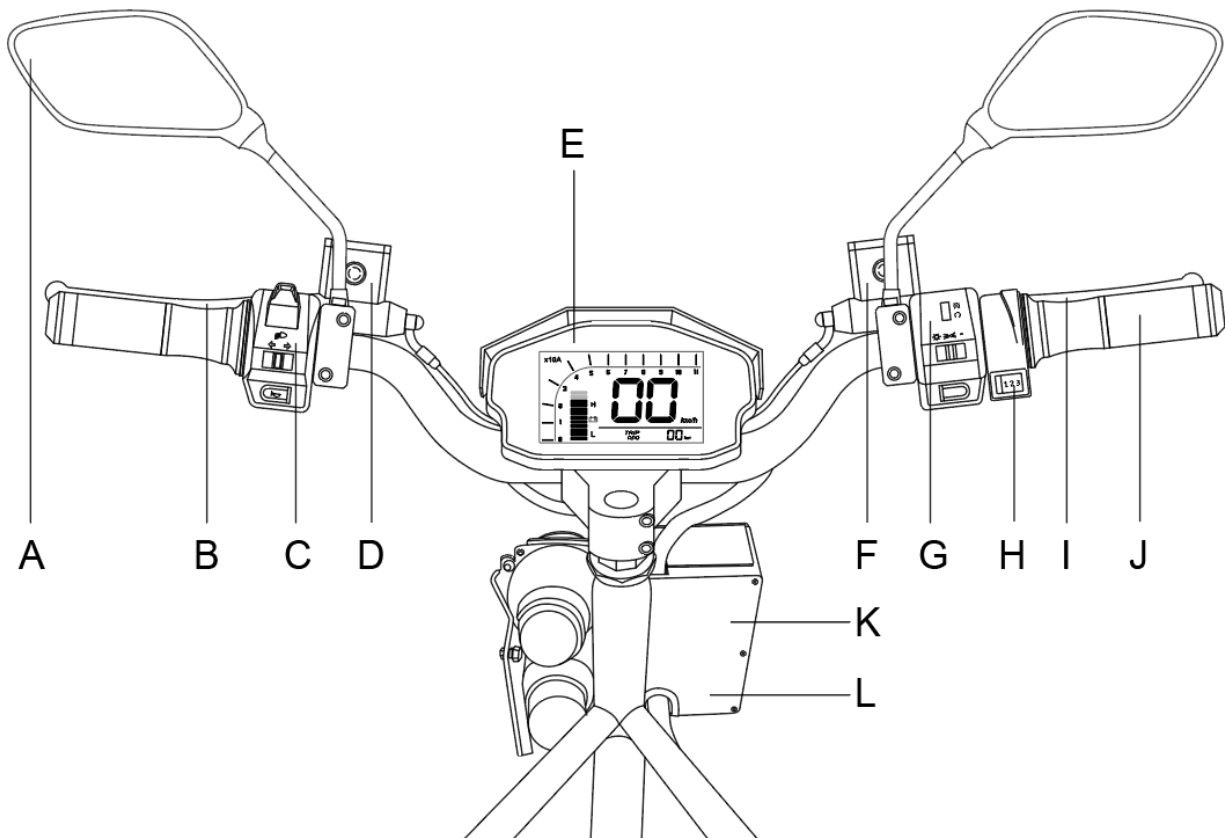

- A. Mirrors
- B. [Rear brake lever](#)
- C. [Switch block, left-side](#)
- D. Rear Brake Master Cylinder / brake fluid reservoir
- E. Dash - see Equipment, Dash
- F. Front Brake Master Cylinder / brake fluid reservoir
- G. [Switch Block, right-side](#)
- H. Power modes
- I. [Front brake lever](#)
- J. Throttle control / Accelerator
- K. Control Box
- L. [Power-On Sensor OR Ignition](#)

## Speedometer / Display

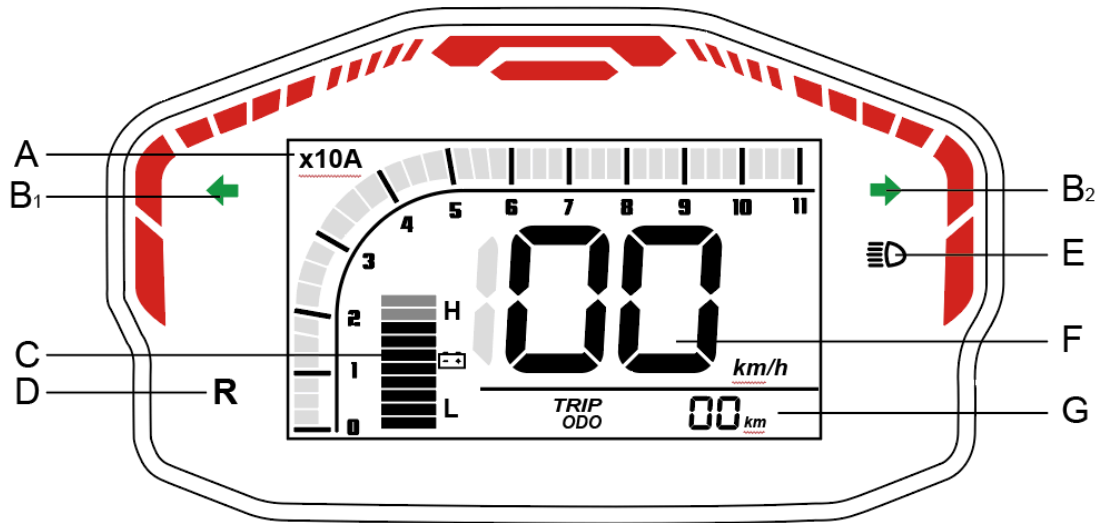

- A. Power / Regen (A) [\(x10\)](#)
- B. Indicators
- C. Powerpack % (x10)
- D. Reverse
- E. High beam
- F. Speedometer

- G. Odometer / Trip

Red light displays speed up to 50 km/h for quick visual of urban riding at lower speeds  
Centre light will stay engaged at 50km/h

^White light displays. Current drawn being x10

## Switch blocks

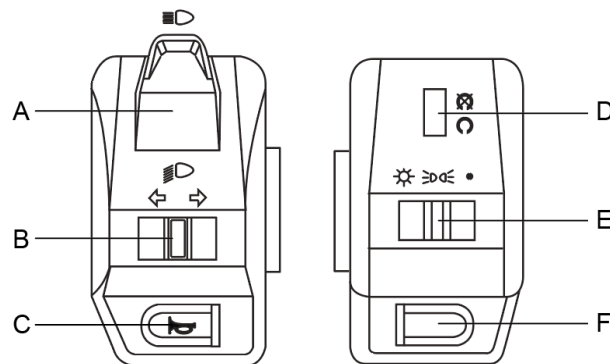

- A. High/Low beam switch
- B. Indicator switch
- C. Horn
- D. Kill Motor switch
- E. Light switch
- F. Reverse mode

# Vehicle Identification

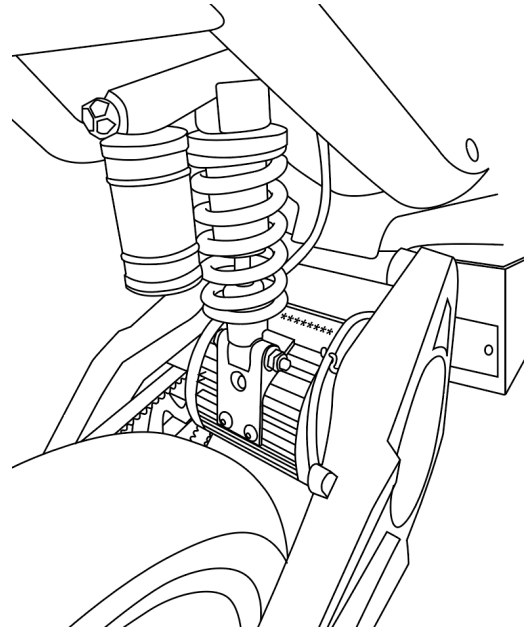
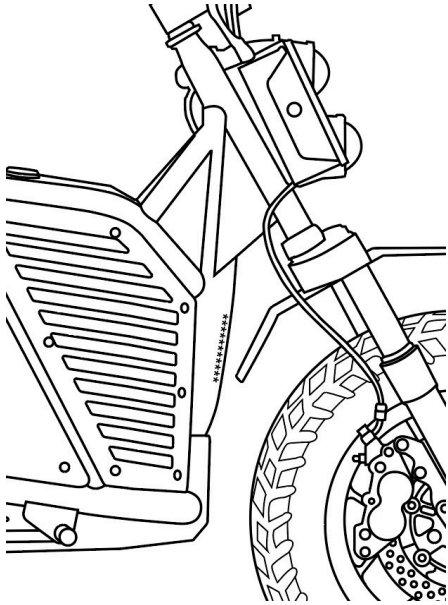

## VIN number

The VIN is a 17-digit number stamped on the front down tube of the vehicles frame. You **must not** alter or remove this number as it is the legal identifier for your motorcycle.

## Motor serial number

The motor serial is an 18-digit number laser etched on the motor housing and is visible when the motorcycle is fully assembled.

## Compliance plate / SVI

The compliance plate or secure vehicle identifier (SVI) is located on the right side of rear skid plate. N.b. identifier type varies by build date.

## Powerpack serial number

The Powerpack serial number is located on the Powerpack housing. The bottom serial number is not accessible when the vehicle is assembled.

# Digital Key / Key

From the factory, your NKD was supplied with

1. Digital Key NFC (vehicles delivered from 06/23). Contactless digital ignition lock Provides maximum security and convenience for your motorcycle. The learning other keys requires at least one learned key.



(\*2).  
of

OR

2. Digital Key & Program Key Fob (vehicles delivered to 05/23)  
One tamper-proof **BLACK** digital keyfob for signalling the bike to turn on and one **RED** programming keyfob. The programming keyfob is required to program new keyfobs to the vehicle's security system. The programming keyfob must never be placed next to the ON sensor of the vehicle and the **BLACK** digital keyfob. The programming keyfob is an essential part of the vehicle system. Without which you will not be able to program new keys for your vehicle security system. Store in a safe place away from the vehicle.



OR

3. Standard Key  
Two sets of identical Black keys. These black keys are the **ONLY** ones you should use in the ignition to start the vehicle

AND

4. Saddle keys  
Two sets of identical black keys to unlock saddle plate and access powerpack and undersaddle secure storage

## IMPORTANT

If your vehicle is fitted with an ignition, turn the key to OFF position before connecting or disconnecting the Powerpack connector.

If your vehicle is fitted with digital ignition, switch the vehicle off via keyfob prior to connecting or disconnecting the Powerpack connector. The tamper proof keyless entry system is powered by an auxiliary battery.

## TIP - Digital key

If you have not ridden your NKD for a while, you may find the vehicle not powering on by digital key. Follow up by pressing and holding the undersaddle override switch, and tap digital key to control box sensor concurrently

# Range & Performance

The range of an electric vehicle is defined as the distance the vehicle travels on a single full charge of the Powerpack.

Like all vehicles, mileage will vary depending on your riding habits and conditions. Your range results are a direct reflection of your riding habits. The more conservatively you ride, the better range you can expect from your NKD. Some of the factors which affect range include: speed, acceleration, number of starts and stops, ambient air temperature, terrain, tyre pressure and load are all important considerations.

We suggest that you ride conservatively as you get to know your NKD. Once you become familiar with the range versus performance of your vehicle, then you can adjust your riding characteristics if you desire. This applies mainly to riders with trip profiles which are at the edge of the performance envelope.

The reported riding range is calculated using industry standard test procedures of 'City Riding' which is specified to determine riding during operation typically found in urban areas of stop/start. Actual range will vary based on riding conditions and habits.

*Fonz is conducting further testing at 89 km/h with the test running on a single charge, in order to report the associated measured range values in higher speed "Highway Riding" conditions. Range values labeled will include "Combined" and will be based on a calculation that assumes a duty cycle comprising 50% City / 50% Highway.*

## Maximising Range

Your real world range will be most positively impacted by using Fonz's regenerative braking system to your advantage.

**You will maximise this energy-recovering function by setting up to come into a stop early, therefore electronically braking gently and using the 'manual' brakes only when necessary, such as an emergency stop.**

Other suggestions to increase your range below.

TIP See article [What impacts the range of an electric motorcycle?](#)

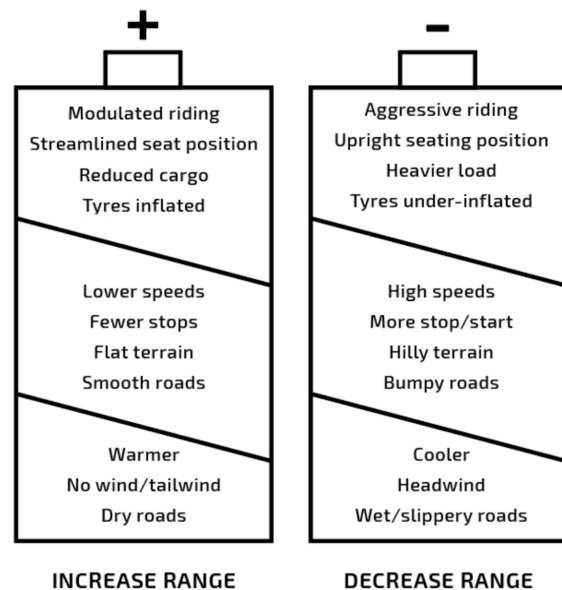

# Starting procedure

1. Mount the vehicle
2. Tap digital key against control box sensor OR Insert the physical key and turn clockwise
3. Move side-stand to stowed position.
4. Ensure the **motor-stop** is in the RUN position.
5. Ensure no warning lights are on
6. Ensure mirrors are adjusted for optimal visibility

Your NKD is now ready to ride.

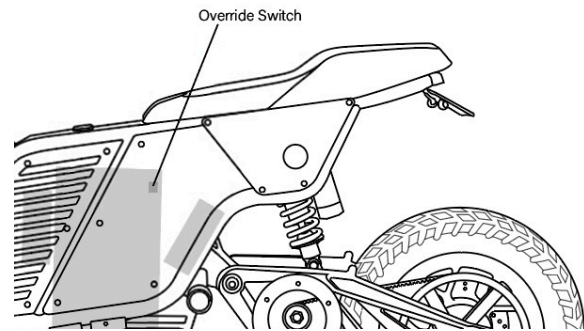

## TIP - Digital key

If you have not ridden your NKD for a while, you may find the vehicle not powering on by digital key. Follow up by pressing and holding the undersaddle override switch, and tap digital key to control box sensor concurrently



## Riding

- Place your feet on your preferred foot pegs (front or rear)
- Slowly and smoothly open the throttle to accelerate
- Close throttle to coast; momentum will continue to carry you forward

## Braking

1. For slow (optimal regenerative) braking under normal conditions, close throttle and smoothly apply pressure to both front and rear brake control levers
2. For maximum braking, close throttle and apply firm pressure to both front and rear brake control levers
3. Ensure that you shift your body weight to a stable position and brace against the force of deceleration to maintain control of the NKD

### TIP

Independent use of the front or rear brake reduces performance and control when stopping. Always use both front and rear brakes together. If one wheel begins to lock or slip, reducing pressure to the corresponding brake control lever will correct the action, and maximise control when stopping. This will become more intuitive with experience. Brake before entering a turn, as firm application of brakes mid-turn may result in loss of control. When braking in wet conditions or on loose surfaces, all braking manoeuvres must be smooth, as sudden application of brakes may result in loss of control.

### TIP Hill Start

When applying either brakes the vehicle won't accelerate. From a hill start engage throttle lightly and then release brake to take off

## CBS Brake System

Vehicles with a frame build date of 10/2021 onward are fitted with a combined braking system (CBS). This system links the front and rear brakes on the vehicle.

This is distinct from the preceding hydraulic brake, where applying

pressure to either the front or rear brake lever will only apply braking force to the corresponding brake.

In the CBS system, the rider's action of depressing the rear brake lever applies both front and rear brakes.

Applying the rear brake lever only will give an 8% bias towards the rear brake

(46% braking effect on the front wheel and 54% braking on the rear wheel).

This is a safe spread of braking force/brake performance rather than utilising the front only or rear only brake levers in a conventional motorcycle.

More lever pressure would be applied to the left lever in order to achieve more balanced braking when using both levers. The two larger caliper pistons take over on a front lever application

rather than the smaller front caliper piston when applying the CBS.

Applying the right brake lever brake only (front brake only) will give 100% braking effect on the front wheel.

For equipment location see [Handlebar Controls](#)

**IMPORTANT** Please get to know your vehicle by riding conservatively as you get to know your vehicle. See further information on [getting to know your vehicle](#)

## Adjusting Brake Levers

Use the lever adjuster to set up comfortable brake lever position by adjusting and selecting from the 6 positions

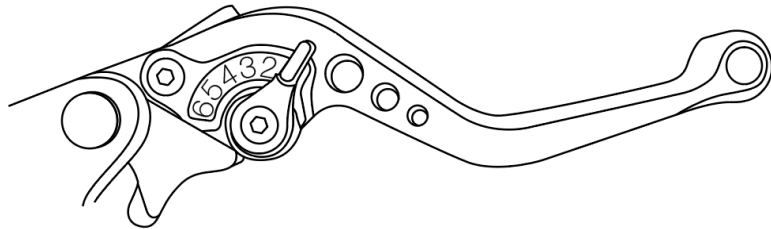

## Reverse & Parking

1. After coming to a complete stop, hold down the BLUE reverse button.
2. While holding reverse, slowly open the throttle.
3. The NKD will travel in reverse at a slow pace.

**TIP:** Reverse will only engage when vehicle is stopped and after front and rear brakes have been released

Engage brakes to return to Ride mode

## Regenerative braking

Regenerative braking is engaged automatically when brake levers are applied, improving efficiency by returning energy to the PowerPack that would otherwise be wasted. For slow (optimal regenerative) braking under normal conditions, close throttle and smoothly apply pressure to both front and rear brake control levers.

### Regenerative Display

White light displays power being returned to x10 Amps

## Power modes

Power modes relate to power output and top speed. Power modes can be switched before, during and after riding.

1. Eco Mode: This mode is for economical riding, limiting torque and max speed to 40 km/h
2. Street Mode: This mode is most suited to urban riding with excellent starting torque (Max 80 km/h)
3. Beast Mode: This mode will allow maximum speed and torque (Max 100 km/h). Note: Disabled in NKDa (Max 80 km/h)

## Riding off-road

Riding on unsealed roads is suitable for NKD dual sport setup only. The vehicle must not be submerged in water greater than 150mm (loaded). When riding off-road the water depth must not be greater than 150mm from the ground / base of tyres.

## Foot Pegs

Foot pegs are designed for resting feet. Choose between front and rear foot pegs for ergonomic ride

**⚠ WARNING** Foot pegs are not designed for standing on, jumping on or other stunts. Max load 10kg.

## Parking

Use the sidestand when parking your NKD.

1. Position your NKD on firm level ground. If you park on inclined ground, ensure that the vehicle is stable and front wheel is pointing up-hill
2. Engage the kill switch
3. Swing the sidestand down, and support the vehicle on the sidestand
4. Dismount the vehicle, and turn the handlebars fully to the left
5. Tap the digital key to the control box sensor OR Turn the key to the OFF position and remove

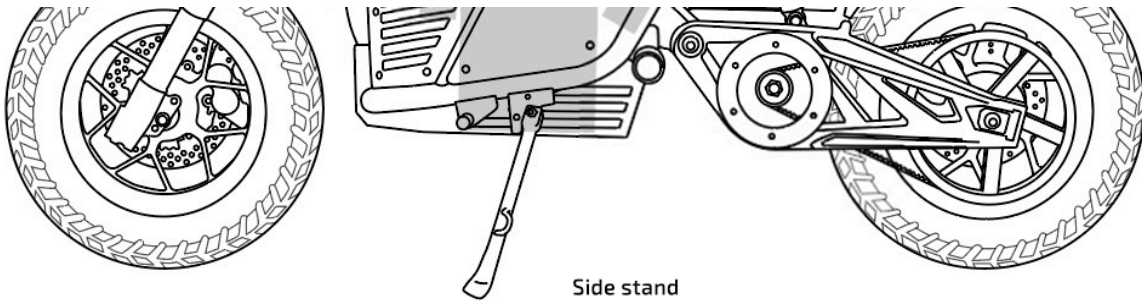

# Charging & Powerpack

## Powerpack Safety & Important Information

### **⚠ WARNING**

Every Fonz Moto charger has been tested before shipping. Please contact customer support immediately if there is any damage or malfunction to the charger and discontinue use immediately.

**⚠ WARNING** Always charge the Powerpack in a location that is well-ventilated and away from combustible materials, liquid. Do not charge the Powerpack out of the vehicle outdoors. Ensure the Powerpack is in a cool, dry place and protected from the elements when charging and stored.

**⚠ WARNING** Liquid must not be stored in Powerpack compartment. If liquid is spilled in the Powerpack compartment, discontinue use immediately. Contact Fonz Moto at [support@fonzmoto.com](mailto:support@fonzmoto.com) to arrange an assessment of the Powerpack

**⚠ WARNING** Only charge the Powerpack with the Fonz External Charger supplied from factory or the Fonz Onboard Charger fitted from factory or approved NKD accessory chargers compatible with the Powerpack. Using unapproved chargers will void the vehicle warranty, and may cause damage to the

Powerpack management system, Powerpack failure, or even fire.

### **⚠ WARNING**

You must only use the charger supplied by Fonz Moto. Do not use aftermarket products with the powerpack. Aftermarket products that have not been rigorously tested may cause

### **IMPORTANT**

Dispose of the Powerpack according to your state and local laws. It is important to recycle the Powerpack rather than disposing of it in landfill. Please contact Fonz Moto at [support@fonzmoto.com](mailto:support@fonzmoto.com) or locate a recycling center in your area.

### **Powerpack service**

The Powerpack is a lithium ion power system. It must only be maintained and serviced by a Fonz Moto certified Powerpack technician. Do not open the Powerpack. Ensure to keep up with the [Fonz Moto Service Schedule](#)

**TIP** After rapidly discharging the Powerpack, e.g. riding for greater than one hour in high temperatures (e.g. < 40°C), allow the Powerpack time to cool before recharging.

## External Charging Port

External Charge Port is compatible with Fonz Moto external chargers. It is not compatible with the Onboard charger.

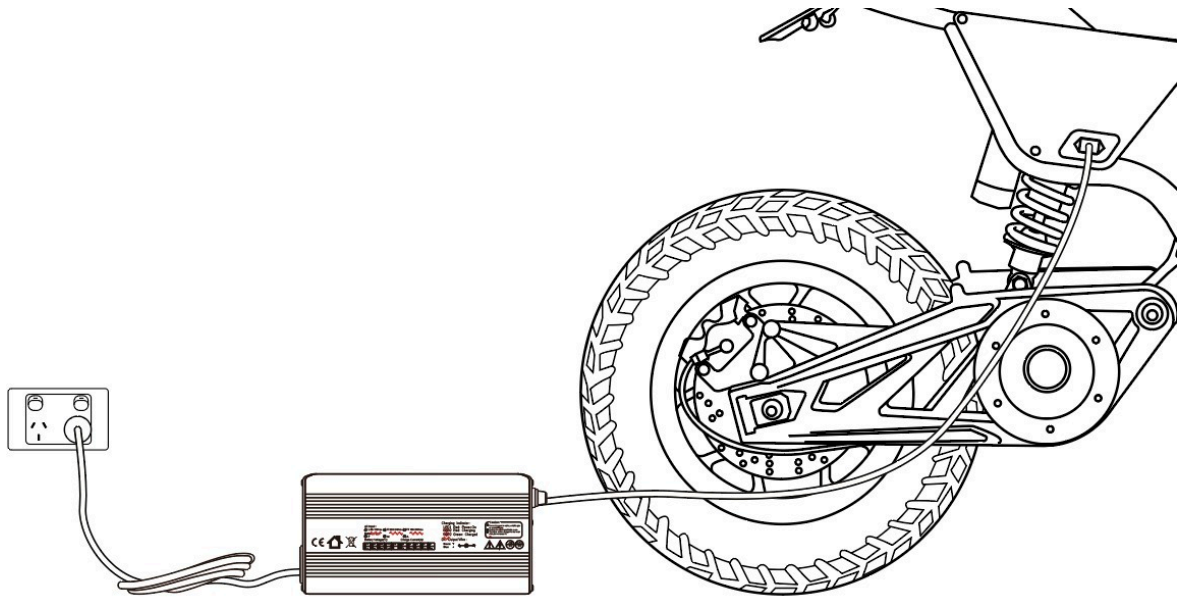

### Mini charger

External compact mini charger. Connect Charger between a standard power outlet (240V) to the external charging port of the vehicle. Charge times vary by model.

### Premium charger

External compact charger (2X faster). Connect Charger between a standard power outlet (240V) to the external charging port of the vehicle. Charge times vary by model.

### Fast charger (only available for NKD+ and NKDx)

External charger (5X faster). Connect Charger between a standard power outlet (240V) to the external charging port of the vehicle. Charge times vary by model.

### Onboard Charger

Durable and waterproof onboard trickle charger with the connecting plug located at the front of the vehicle (see image).

Comes with a travel cable to connect between the onboard charger and standard 240V power outlet to bike. The travel cable can be stored under the saddle.

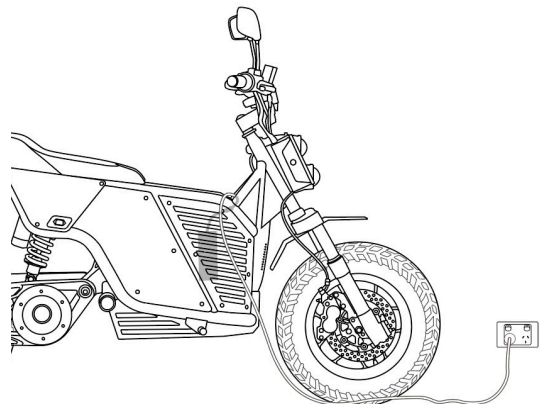

⚠ **WARNING** Onboard Charger is not compatible with [External Charging Port](#).

⚠ **WARNING** Do not try to force the Onboard charger travel cable into the external charging port

## Charging Indoors

NKDa has a portable Powerpack designed to charge indoors.

Other Powerpacks are designed to charge directly via External Charging Port

- NKDs is designed to charge with the powerpack installed in the vehicle. The Powerpack may be removed in required to charge indoors
- NKD+ is designed to charge with the powerpack installed in the vehicle. The Powerpack may be removed to charge indoors
- NKDx Powerpack is not designed to remove from vehicle.

## Removing Powerpack

1. Insert the key into saddle opening keyhole
2. Lift the saddle plate
3. Turn off the bike prior to removing or charging Powerpack
4. Ensure PowerPack safety switch is set to the OFF position (NKDa only)
5. Use handle to lift PowerPack out of bike

## Charger Specifications

Charger	Specification	Compatibility	Charge time to 100%
Mini	4A, input 240V, max 450W	All models	NKDa (~5hrs) NKDs (~10hrs) NKD+ (~15hrs)
Premium	8A/10A, input 240V, max 900/1100W	All models	NKDa (~2hrs) NKDs (~4hrs) NKD+ (~6hrs) NKDx (~8hrs)
Fast	20A, 240V, max 2200W	NKD+ / NKDx	NKD+ (~3.5hrs) NKDx (~4.5hrs)
Onboard	4A, 240V, max 450W	Factory fitted vehicles only	NKDa (~5hrs) NKDs (~10hrs) NKD+ (~15hrs) NKDx (~20hrs)

Fonz chargers sold in Australia are only designed to be used in Australian 240V power outlets with Fonz Powerpack.

**⚠ WARNING** Make sure the voltage from the AC outlet matches that required by the charger (240V). Fonz is not responsible for any improper operation.

## Charger Operation

Make sure the charger is firmly connected to the charging port.

The charger will be turned off automatically after the Powerpack is fully charged.

Unplug the charger from 240V AC power outlet when the charger is not in use.

External Chargers are not designed to be stowed onboard the vehicle.

Unplug the charger from 240V AC power outlet before unplugging the Powerpack / charging port.

**⚠ WARNING** If you are not riding the bike for extended periods of time, you should leave the charge % between 60-80%. In case of malfunction, please contact customer support immediately. Never store PowerPack below 20% for more than a week. Once 0% is reached, charge immediately.

## TIPS

For a longer service life if your Powerpack is equipped with an off switch, prevent arcing wear and tear on the power connector by turning the off switch to OFF position when the power connector is being connected / disconnected to charge indoors (NKDa only).

If your vehicle is fitted with an ignition, turn the key to OFF position before connecting or disconnecting the Powerpack connector.

If your vehicle is fitted with digital ignition, switch the vehicle off via keyfob prior to connecting or disconnecting the Powerpack connector.

## External Charger Safety Information

- NEVER store the charger outdoors. Always store in a cool and dry indoor environment when not in use
- DO NOT place the output cable, power cord or charger on a wet surface
- NEVER use the charger with defective power cord and/or damaged wires
- DO NOT use in extremely humid conditions
- DO NOT place the charger directly in sunlight
- NEVER use the charger near flammable and explosive areas
- ALWAYS keep the charger vent 10cm away from other objects. DO NOT cover



- Unplug charger from AC outlet before attempting any maintenance or cleaning.
- Place the charger in a clean and ventilated environment while charging.
- Plug in and unplug the AC power cord by grasping the plug.
- Do not drag the power cord itself to reduce risk of damaging power cord.
- Charger is designed for indoor usage, must not be stowed on-board

*These techniques will ensure system integrity and precisely control the charging voltage and current. The Powerpack will be fully charged but not overcharged. Frequent charging will not affect life cycles. From time-to-time ensure discharging calibrate cells to PowerPack management system by charging & discharging 100%-5%.*

*The warranty is void if:*

- Operation instructions are not followed
- Warranty period has passed
- Damage is caused by improper operation
- Damages caused by force majeure
- Service schedule is not kept up

# Suspension

## Rear Mono Shock Absorber

### Spring Preload Adjustment

1. Use an adjusting wrench to loosen the upper 'locking' collar
2. To adjust, use the adjusting wrench to turn the lower 'adjusting' collar
3. For sag measurements less than the standard setup, decrease the preload on the spring by turning the adjustment collar counter-clockwise on the shock. If more than the standard setup, increase the preload on the spring by turning the adjustment collar clockwise on the shock.
4. Once the lower collar is adjusted to preferred setting, fasten the locking collar against adjusting collar

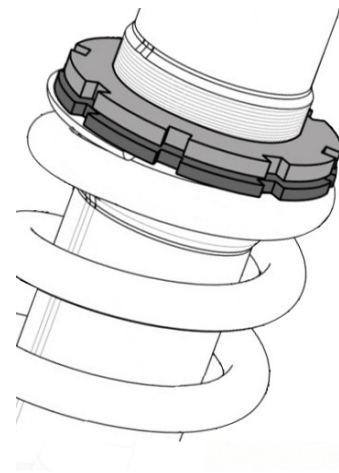

⚠ **WARNING** Ensure the spring adjustment nut is tight against the spring before riding the vehicle

**TIP** Clean any dirt or debris from the slots of the shock adjusting collar before adjusting

### Rebound Adjustment

The rebound 'tension' damper adjuster screw is located at bottom of the shock.

Printed on the shock, is "F" meaning faster rebound and "S" meaning Slower rebound.

Use a flathead screwdriver to adjust the rebound.

F **Faster** rebound and a softer ride, is better for big impacts

S **Slower** rebound and a firmer ride, is better for smaller and more frequent impacts

Note: There are 15 clicks of adjustment. The adjustor should never be forced completely; always leave one click of adjustment in either direction

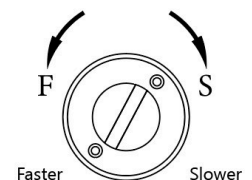
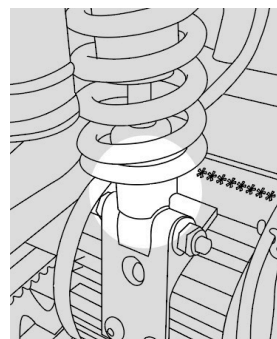

## Compression Damper

The compression damper adjustment screw is at the top of the piggyback.

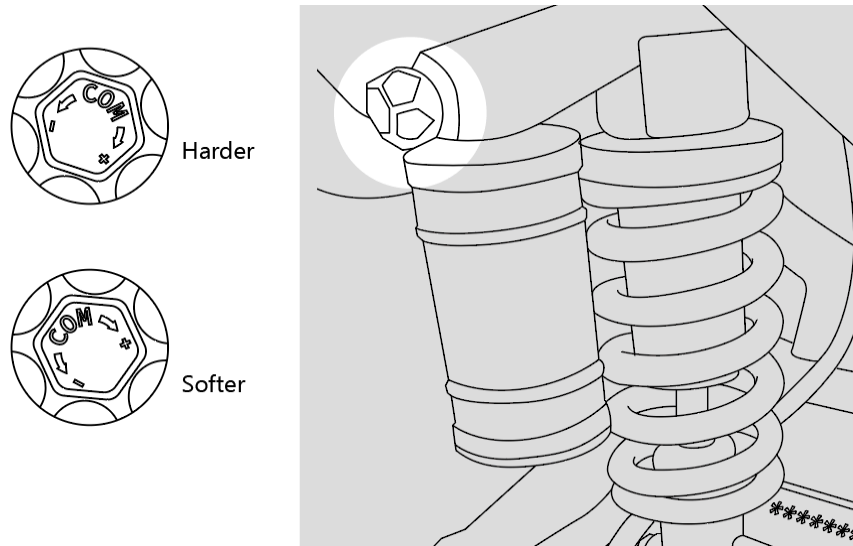

Printed on the shock, are the symbols + and -

- + **Harder**, for slower rebound. Turn clockwise, or + direction, for better performance in big impacts
- **Softer** for faster rebound. Turn counter-clockwise, is better for smaller and more frequent impacts

There are 14 clicks of adjustment. If you set the Compression adjustment too hard it may 'pack-up' and become harsh over consecutive bumps. While compression that is set too soft may cause the shock to bottom out harshly with load.

**⚠ WARNING** Do not adjust to the maximum in any direction. Allow one click before maximum or minimum.

### Factory Supplied Rear Suspension Settings

The following information will allow you to adjust the rear suspension back to the factory settings.

Adjustment	Setting
Shock Rebound	Max minus 10 clicks counterclockwise
Rear Shock Compression	Max minus 8 clicks counterclockwise

# Tyres & Wheels

## Tyre Inflation

	Street	Dual Sport
Front Tyre	32 PSI	30 PSI
Rear Tyre	34 PSI	32 PSI

## Tyre Tread Depth

Tread depth should be greater than 1.6 mm.

## Tyre Care and Replacement

Inspect both wheels and tyres regularly. If any of the below conditions are observed, see your authorised repairer to replace the wheel or tyre immediately:

- Bends or cracks.
- Worn tread below 1.6mm
- Impact marks.

Inspect both tires for the following:

- Cuts, cracks, splits, or missing tread lugs in the tread or sidewall area.
- Bumps or bulges within the tire body.
- Uneven tyre tread wear. Wear on one side of the tire tread or flat spots in the tire tread indicate a problem with the tire or motorcycle.
- Exposed tire thread or cords.
- Tread depth below 1.6 mm

If either of the wheels or tyres are found to have any of the above conditions, replace the wheel or tyre immediately.

### **WARNING**

Installation of non approved tyres may cause adverse handling and performance issues.

# Storage, Convenience & Accessories

All genuine FONZ accessories and authorised products are designed and tested to ensure that each is fit for use. Fonz Bikes cannot be held liable for incompatibility, or damages incurred by the use of non-approved accessories or improper use

## Under saddle storage compartment

Lockable and water-resistant. Suitable for riding gear, gloves etc.

## Front storage

Non waterproof storage. Optional pouch to be fitted for quick access items without opening under saddle storage

## Bag Mounts

Fasten bag over pillion passenger seating position with tie downs and mounting hooks.

## Tank Bag

Fasten bag over front saddle plate with tie downs and mounting

## Smartphone Mounts

## Saddle plate

Weatherproof Wireless Charging Head comes with everything needed to install to a Quad Lock Motorcycle Mount

## Mirror handlebar / mount

glassless mirror series mo.view

